



This manual has been scanned by the
Vickers MG Collection & Research
Association

www.vickersmachinegun.org.uk

If it is of use, please make a donation at:

https://www.paypal.com/cgi-bin/webscr?cmd=s-xclick&hosted_button_id=NKSHEDAMHTJ3G

**RESTRICTED**

The information given in this document is not to be communicated, either directly or indirectly, to the Press or to any person not authorized to receive it.

Small Arms Training

Volume I, Pamphlet No. 21

The Machine Carbine

1944

(This pamphlet supersedes S.A.T. Vol. I Pamphlets Nos. 21 and 22, 1942)

DISTRIBUTION

All Arms	Scale 1
All O.C.T.U.s.	Scale 1
O.C.T.U.s.	Scale 1
S.A.S., Hythe Wing	650
S.A.S., Netheravon Wing	25
School of Infantry	25

CONTENTS

	PAGE
General Notes	1
SEC.	
1. The Thompson Machine Carbine :—	
Lesson 1.—Loading and unloading	2
Lesson 2.—Firing	5
Lesson 3.—Stripping and cleaning	9
2. The Sten Machine Carbine :—	
Lesson 1.—Loading and unloading	11
Lesson 2.—Firing	14
Lesson 3.—Stripping and cleaning	19
Appendix A.—The Thompson Sub-machine Gun M.1 (U.S. model)	21
Appendix B.—Fitting of the Spotlight Projector	21
Appendix C.—Sten Machine Carbine—New Cocking Handle Mark IV	27
Appendix D.—Danger area—Thompson and Sten Machine Carbines	28

SMALL ARMS TRAINING, VOLUME I,
PAMPHLET No. 21

THE MACHINE CARBINE

GENERAL NOTES

1. **Object.**—The sole object of weapon training is to teach all ranks the most efficient way of handling their weapons in order to kill the enemy. Instructors will always bear this fact in mind and will continually impress it upon those whom they instruct.

2. General description.

Thompson Machine Carbine.—Calibre : .45 in. Weight : 10 lb. approx. (Plate 1).

Sten Machine Carbine.—Calibre : 9 mm. (.35 in.). Weight : 6½ lb. approx. (Plate 2).



PLATE 1

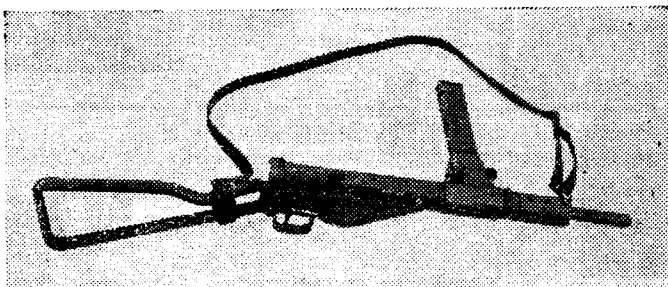

PLATE 2

The main points of difference between the Sten, Marks I, II and III are as follows :—

Mark I.—Fixed barrel with full length casing, perforated and fitted with sling swivel, flash eliminator, and foresight protectors. Wooden fore-end with folding forward hand grip. Skeleton butt; fixed magazine housing.

Mark II.—No woodwork, removable barrel with no flash eliminator. Tubular butt. Foresight at fore-end of breech casing.

Mark III.—Breech casing continued forward to form barrel casing with a rib running full length along the top; foresight, with no protectors, at muzzle end.

Trigger mechanism casing not fixed by screws, but sprung on. Mark II type of butt.

Mark V.—As Mark II with wooden butt and pistol grips, Mark IV cocking handle (*see* Appendix C), foresight with protectors as for No. 4 rifle. Takes bayonet for No. 4 rifle. Pistol grips removable by armourer. Plate provided to enable carbine to be fired without butt. Butt trap for oil-bottle and pull-through.

3. Characteristics.—The machine carbine is a short range weapon used to engage enemy at ranges up to 100 yards. At greater distances the penetrative power of the bullet is considerably reduced.

It is an ideal weapon for street fighting, wood clearing, or patrols. Under these conditions the enemy may appear suddenly at close range and in different directions, and can be attacked immediately by fire from the shoulder without using the sights, or from the waist.

The carbine is an automatic weapon operated by blowback action, and it can be fired in single rounds or bursts.

4. Training.—Instructors must appreciate that while the lessons are designed to be taught in one period, more time will be necessary to allow sufficient practice to obtain proficiency. The spotlight projector can usefully be employed to teach correct holding (*see* Appendix B).

5. Safety precautions.—At the beginning of every lesson the instructor will inspect the carbine, magazines and pouches.

SECTION 1.—THE THOMPSON MACHINE CARBINE

LESSON 1.—LOADING AND UNLOADING

Instructor's notes

Stores :—

Thompson machine carbine with sling fitted; magazines.

Live ammunition may be used for teaching magazine filling ONLY.

Its use must be carefully supervised and in no circumstances will it be used for any other purpose.

All parts will be named as they are dealt with. (Plate 3.)

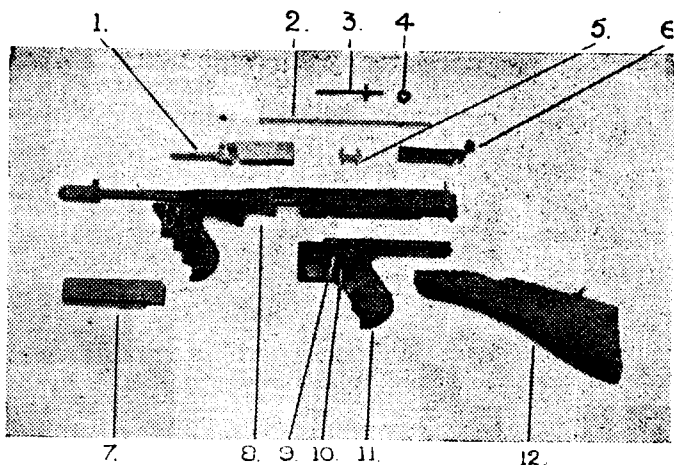

PLATE 3

Key to Plate 3

- | | |
|--------------------|---------------------|
| 1. Bolt. | 7. Magazine |
| 2. Spring. | 8. Barrel and body. |
| 3. Buffer. | 9. Change lever. |
| 4. Buffer washer. | 10. Magazine catch. |
| 5. "H" piece. | 11. Pistol grip. |
| 6. Cocking handle. | 12. Butt. |

1. Explain general notes, para. 3.

2. Magazine filling.

(a) Explain and demonstrate :—

To fill.—Hold the magazine in the left hand, ribs away from the body. Pick up a convenient number of rounds in the right hand and ensure that they are clean. Place each round in the top of the magazine, base first; then press it downwards and backwards into place. Count the number of rounds. The magazine holds 20 rounds.

To empty.—Press each round forward with the nose of a bullet, or remove with finger and thumb.

(b) Practise squad.

3. Loading, "ready" position, and unloading.

(i) Explain and demonstrate :—

To load.—Hold the Thompson with the right hand on the pistol grip, forefinger outside the trigger guard, butt under the arm, and barrel pointing to the front and downwards. Turn the Thompson to the right, take the magazine in the left hand, ribs to the rear, and insert it in the recess in front of the trigger guard. Push the magazine in and ensure that it is fully home.

Carriage.—The Thompson can be carried :—

- (i) Slung over the shoulder.
- (ii) At the trail, like the rifle, or upside down.
- (iii) In front of the body with the sling round the neck.

When the enemy is likely to be met, the "ready" position can quickly be adopted from any of these positions as follows :—

Bring the weapon close in to the right side with the butt under the arm and the barrel pointing to the front. Pull back the cocking handle, grasp the foregrip with the left hand, and put the right forefinger on the trigger.

To unload.—Return to the loading position and turn the Thompson to the right. Press the magazine catch on the left side of the pistol grip upwards and remove the magazine. Cock the Thompson if it is not already cocked ; then, holding the cocking handle with the left hand, press the trigger, and ease the working parts forward under control. Repeat this action.

(b) Practise squad. (Words of command : " Load "—" Slung position," etc.—" Ready "—" Unload ".)

4. The sights.

Explain :—Some Thompsons have a fixed aperture backsight for ranges up to 100 yards. The rule for aiming is as for the L.M.G. Others have an adjustable tangent backsight. This is unnecessary and should never be used ; use instead the V-shaped recess in the cocking handle. (Rule for aiming as for the No. 1 rifle, see Pamphlet No. 3, Lesson 3.)

LESSON 2.—FIRING

Instructor's notes

Stores :—

Thompson machine carbine with sling fitted; magazines; three Fig. 2 targets.

To enable the working parts to go forward when the trigger is pressed the magazine platform will, where necessary, be depressed with a halfpenny wedged under the magazine lips. The breech should also be padded with a wad of cotton waste or paper to prevent damage to the bolt.

1. Firing positions.

Explain :—There are three methods of firing the Thompson, as follows :—

- (a) From the shoulder, using the sights as taught. (Plate 4).
- (b) From the shoulder, roughly aligning the barrel on the enemy but without using the sights.
- (c) From the waist, by sense of direction. (Plate 5).

The position used will depend on the circumstances. Always use the sights if time permits, and fire from the waist only when speed is of great importance. In an emergency fire can be applied from the waist on the move, but if it is possible to halt momentarily, greater accuracy will result.

2. Types of fire.

Explain :—If the change lever is pushed forward, the Thompson will fire bursts; if backward, in single rounds. (The change lever can be moved backward only when the action is cocked.)

Normally the Thompson will be fired in bursts, and in the field the change lever should be set at "Automatic." Bursts should rarely be of more than two or three rounds. There will be occasions, however, when single rounds, fired from the shoulder, will be sufficient to deal with the enemy.

3. Firing.—Explain and demonstrate from the "ready" position :—

- (a) *Firing from the shoulder, using the sights.*—The position and method of firing is the same as for firing the rifle, except that the enemy should be faced squarely. When the enemy has been dealt with, continue to advance at the "ready" position. If the enemy is not likely to appear

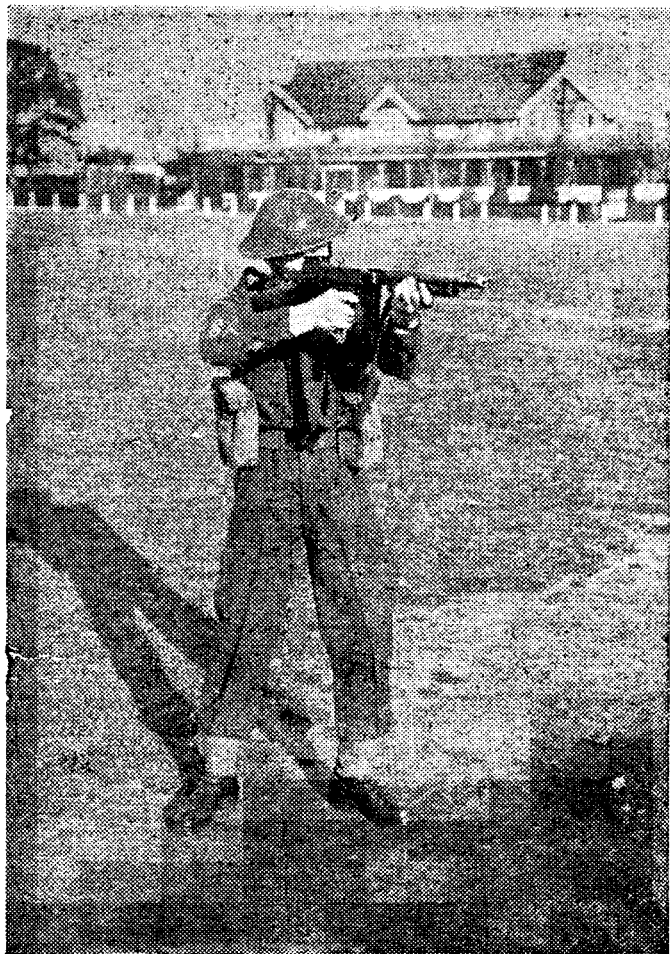

PLATE 4



PLATE 5

again, remove the magazine, ease the working parts forward, and replace the magazine, or, if necessary, a fresh one.

Practise squad at the halt and on the move, emphasizing the need for speed in coming into action. (Words of command: "Load"—"Ready"—"Fire," etc.—"Unload.") The Thompson should be re-cocked each time after firing.

- (b) *Firing from the shoulder, roughly aligning the barrel.*—When the enemy appears, swing the body from the waist, at the same time bringing the Thompson into the shoulder and quickly pointing the muzzle at the enemy. The position of the feet is immaterial, provided that balance can be maintained. While firing, observe the strike of shots if possible, and correct the alignment of the barrel as necessary.

Practise squad. (Words of command: "Load"—"Ready"—"Target right," etc.—"Fire"—"Miss low," etc.—"Advance" . . .) The instructor must check for direction.

- (c) *Firing from the waist.*—Swing the body from the waist as before, and fire straight from the "ready" position. Since firing is entirely by sense of direction, every effort should be made to observe results.

Practise squad as in (b).

NOTE.—Whenever possible full use should be made of the spotlight projector (see Appendix B). This enables the instructor to check, and the firer to see his own mistakes.

4. Immediate action.

- (a) Explain and demonstrate:—When the magazine becomes empty the Thompson will stop with the cocking handle to the rear. The remedy is simply to change the magazine and go on firing.

If the Thompson stops before the magazine is empty, cock it and look quickly into the chamber. If there is no obstruction, go on firing.

Practise squad. (Words of command:—"Thompson fires all right"—"Thompson stops"—"Thompson fires all right". The firer will apply Immediate Action according to the position of the cocking handle).

- (b) If, after cocking and looking into the chamber, there is an obstruction, turn the Thompson to the right and shake vigorously; the round or empty case should fall out. If it does, and the chamber is clear, go on firing. If the obstruction is still there, or if there is a live round in the chamber, remove the magazine; any obstruction will drop out. Fire the live round and re-cock if necessary, replace the magazine and go on firing.

- (c) A misplaced round in the magazine will be flicked out and any round half-fed in the chamber shaken out; and in either case the round will not be replaced in the magazine. These rounds will be regarded as damaged, whether any signs are visible or not, and as such will be rejected.

NOTE.—In darkness feel inside the ejection opening to make certain that the obstruction has been removed.

Practise squad. (Words of command:—"Thompson fires all right"—"Thompson stops"—"Obstruction"—"Clear"—"Live round in chamber", etc.—"Thompson fires all right").

LESSON 3.—STRIPPING AND CLEANING

Instructor's notes

Stores:—

Thompson machine carbine; magazines; pull-through; flannelette and oil (oil can in butt trap); chamber cleaning brush; gauze; graphited grease; nail.

Buffer rods are drilled with a hole $\frac{1}{8}$ in. in diameter, $\frac{3}{8}$ in. from the forward end of the rod, at right angles to the flat of the buffer collar, to enable a nail to be used for removing and replacing the recoil spring.

For names of parts, see Plate 3.

1. Stripping.

- (a) Explain and demonstrate:—Cock the Thompson and ease the working parts forward. This must always be done before any part is stripped. Make certain that the change lever is forward (if it is not, the tripping lever may be damaged during stripping). Depress the butt plunger and remove the butt. Turn the Thompson upside down; depress the pistol grip plunger and remove the pistol grip, keeping the trigger pressed. Assemble in the reverse order.

- (b) Practise squad.

- (c) Explain and demonstrate:—After removing the butt and pistol grip, draw the bolt back till its rear end meets the hole in the buffer rod. Insert the nail into this hole through the recoil spring. Allow the bolt to go forward and draw the buffer forward till its rear end is clear of the hole in the body. Remove the buffer and spring. Keeping the spring under control, remove the nail and slide off the spring.

Draw the working parts to the rear and lift out the bolt. Push the cocking handle forward till the "H" piece rises; lift it out. Bring the cocking handle to the rear and lift it out.

Assemble in the reverse order as far as the bolt. Place the end of the buffer in its seating **outside** the rear of

the body, with the flat side of the collar downwards. Place the recoil spring over the buffer rod and compress it with the fingers until only two or three inches remain free. Insert the nail into the hole in the rod to keep the spring compressed. Remove the buffer and spring and insert the free end of the spring in the recess in the rear end of the cocking handle. Make certain that the flat side of the collar is downwards, and guide the rear end of the buffer into its seating. Draw the bolt back till it meets the nail. Remove the nail and ease the bolt forward under control.

After completely assembling the Thompson, cock and ease the working parts forward.

(d) Practise squad.

NOTE.—To strip and assemble the latest pattern of Thompson machine carbine, proceed as in Appendix A.

2. Cleaning.

(a) Explain and demonstrate :—Strip the Thompson completely. Clean the bore as taught for the rifle, using the pull-through and flannelette, size 4 ins. by 8 ins. The flannelette should be folded twice until it measures 4 ins. by 2 ins. ; it will then fit the pull-through easily. A gauze is provided but should be used only when absolutely necessary. Before using it, pack it with two pieces of flannelette, size 4 ins. by 2 ins., one piece wrapped round each side of the loop. Place the gauze completely round the flannelette and tuck the ends into the centre of the loop. When the bore is clean, oil it, using flannelette size 4 ins. by 6 ins. folded in three sections. Before firing the barrel should be dry if possible. Clean and oil the chamber, using the brush provided with flannelette placed over it.

Thoroughly clean and oil the rest of the weapon, paying special attention to the following :—

The face of the bolt.

The trigger mechanism.

The two felt pads.

The sliding surfaces of the bolt and the inside of the body.

Use graphited grease on the " H " piece and the recesses into which it fits in the bolt and body.

Assemble the weapon.

Clean the magazines with an oily rag.

(b) Practise squad.

3. Decontamination.

- (a) Explain that if the Thompson becomes contaminated by gas it should be cleaned like the rifle (see Pamphlet No. 3, Lesson 1).
- (b) Question squad.

SECTION 2.—THE STEN MACHINE CARBINE

LESSON 1.—LOADING AND UNLOADING

Instructor's notes

Stores :—

Sten machine carbine with sling fitted ; magazines.

All parts will be named as dealt with (Plate 6).

Live ammunition may be used for teaching magazine filling ONLY. Its use must be carefully supervised and in no circumstances will it be used for any other purpose.

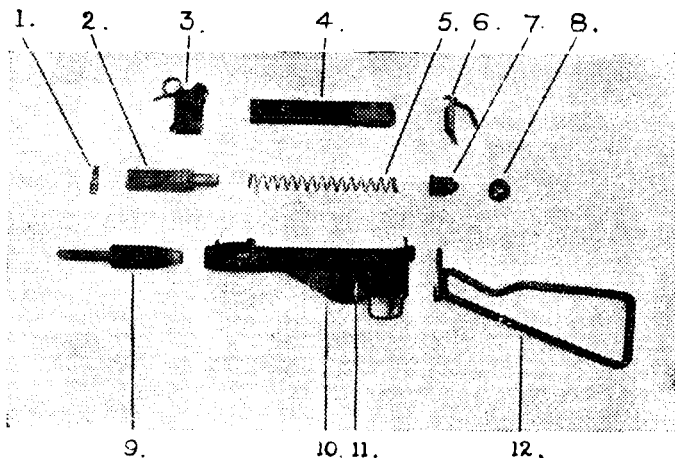

PLATE 6

Key to Plate 6

- | | |
|-----------------------------|---------------------------|
| 1. Cocking handle. | 7. Recoil spring housing. |
| 2. Bolt. | 8. Recoil spring cap. |
| 3. Magazine filler Mark I. | 9. Barrel and barrel nut. |
| 4. Magazine. | 10. Body. |
| 5. Recoil spring. | 11. Stud. |
| 6. Magazine filler Mark IV. | 12. Butt. |

1. Explain general notes, para. 3.

2. Magazine filling.

- (a) Explain and demonstrate:—The magazine spring is too powerful to enable filling to be done quickly by hand; a filler is, therefore, provided. The most common is the Mark IV filler.

To fit the filler: Hold the magazine with the groove towards the body; keeping the nose of the filling lever clear, place the filler over the magazine so that the tongue on the filler fits into the rectangular recess in the magazine. Slide the filler upwards till it engages. If it does not engage easily, lift the filler spring.

To fill the magazine: With the left hand raise the lever to depress the magazine platform. Pick up a convenient number of rounds in the right hand and see that they are clean. Insert a round, base first, *under* the lips of the magazine (NEVER try to force a round downwards between the lips, or they may be damaged.) Lower the filling lever and push the round fully home. Repeat these actions, counting the rounds while filling. The magazine holds 32 rounds. To remove the filler, lift the spring, and slide the filler downwards and off.

NOTE.—The Sten will fire most makes of 9 mm. ammunition, including German and Italian.

- (b) *To empty*.—Remove each round with the thumb and forefinger.
- (c) Practise squad.

NOTE.—The Mark I filler, shaped like a box with a brass lever, may occasionally be met. In this case, fill the magazine as follows:—

Place the filler over the magazine so that the catch on the filler spring engages with the rectangular recess on the magazine. Hold the magazine with the groove pointing away from the body; place the fingers of the left hand on the filling lever with the forefinger through the loop. Press down the lever to depress the magazine platform. Insert a round base first, under the nose of the lever; raise the lever quickly up and down to guide the round into place. Repeat these actions till the magazine is full, making certain that each round is guided into place *under* the lips. (To remove the filler, raise the spring and lift off.)

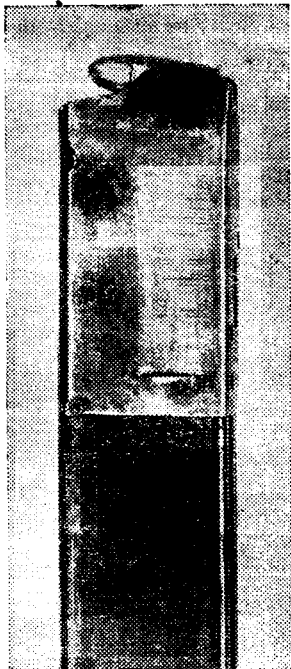

PLATE 7

3. Loading, "ready" position, and unloading.

(a) Explain and demonstrate with an empty magazine:—

To load.—Hold the Sten with the right hand on the butt grip, forefinger outside the trigger guard, butt under the arm, and barrel pointing to the front and downwards. Pull back the cocking handle and move it into the safety slot at the top of the carbine. Take the magazine in the left hand, with the groove to the rear, look to see that the top round is in the correct position (Plate 7), then insert the magazine into the housing on the left side of the carbine. *See that it is fully home.*

Carriage.—The Sten can be carried:—

- (i) Slung over the shoulder.
- (ii) At the trail, like the rifle.
- (iii) In front of the body with the sling round the neck.

When the enemy is likely to be met, the "ready" position can quickly be adopted from any of these positions as follows :—

Bring the weapon close in to the right side with the butt under the arm and the barrel pointing to the front. Release the cocking handle from the safety slot, grasp the barrel nut with the left hand well clear of the ejection opening and the wrist under the magazine, and put the right forefinger on the trigger.

To unload.—Return to the loading position. Depress the catch on the magazine housing with the thumb and remove the magazine. Holding the cocking handle with the left hand, press the trigger and ease the working parts forward under control. Cock and ease the working parts forward again.

NOTE.—If the working parts are forward with a full or partially full magazine in the housing, a round may be fired if the Sten is suddenly jerked or the cocking handle is released prematurely during cocking. The cocking handle, therefore, must *always* be in the safety slot before a magazine is put on the weapon.

(b) Practise squad. (Words of command : " Load "—" Slung position," etc. " Ready "—" Unload ".)

4. The sights.

Explain :—The Sten is fitted with a fixed aperture backsight for ranges up to 100 yards. The rule for aiming is as for the L.M.G.

LESSON 2.—FIRING

Instructor's notes

Stores :—

Sten machine carbine with sling fitted ; magazines ; three Fig. 2 targets.

The breech should be padded with a wad of cotton waste or paper, to prevent damage to the bolt when the trigger is pressed.

1. Firing positions.

Explain :—There are three methods of firing the Sten, as follows :—

- (a) From the shoulder, using the sights as taught. (Plate 8).
- (b) From the shoulder, roughly aligning the barrel on the enemy, but without using the sights.
- (c) From the waist, by sense of direction. (Plate 9).



PLATE 8



PLATE 9

The position used will depend on the circumstances. Always use the sights if time permits, and fire from the waist only when speed is of great importance. In an emergency fire can be applied from the waist on the move, but if it is possible to halt momentarily, greater accuracy will result.

2. Types of fire.

Explain :—The type of fire can be altered by moving the stud on the trigger mechanism casing. By pressing in the side marked " R " the Sten will fire single rounds ; if the side marked " A ", it will fire bursts.

Normally the Sten will be fired in bursts, and in the field the stud should be set at " Automatic ". Bursts should rarely be of more than 2 or 3 rounds. There will be occasions, however, when single rounds, fired from the shoulder, will be sufficient to deal with the enemy.

3. Firing.—Explain and demonstrate from the " ready " position :—

(a) *Firing from the shoulder, using the sights.*—The position and method of firing is the same as for the rifle, except that the enemy should be faced squarely. When the enemy has been dealt with, continue to advance at the " ready " position. If the enemy is not likely to appear again, put the cocking handle in the safety recess. In either case change the magazine if necessary.

Practise squad at the halt and on the move, emphasizing the need for speed in coming into action. (Words of command :—" Load " — " Ready " — " Fire," etc. — " Unload "). The Sten should be re-cocked each time after firing.

(b) *Firing from the shoulder, roughly aligning the barrel.*—When the enemy appears, swing the body from the waist, at the same time bringing the Sten into the shoulder and quickly pointing the muzzle at the enemy. The position of the feet is immaterial, provided that balance can be maintained. While firing, observe the strike of shots if possible, and correct the alignment of the barrel as necessary.

Practise squad as in (a). (Words of command : " Load " — " Ready " — " Target right ", etc.—" Fire " — " Miss low," etc.—" Advance "). The instructor must check for direction.

- (c) *Firing from the waist.*—Swing the body from the waist as before, and fire straight from the “ready” position. Since firing is entirely by sense of direction, every effort should be made to observe results.

Practise squad as in (b).

NOTE.—Whenever possible full use should be made of the spotlight projector (see Appendix B). This enables the instructor to check, and the firer to see his own mistakes.

4. Immediate action.

- (a) Explain and demonstrate.—If the Sten fails to fire or stops firing, cock it and look quickly into the ejection opening. If the magazine is empty, change it and go on firing. If there are rounds in the magazine, push it fully home and go on firing.

Practise squad. (Words of command: “Sten fires all right”—“Sten stops”—“Magazine empty” or “Rounds in magazine”—“Sten fires all right”).

- (b) If, after cocking and looking in the ejection opening, there is an obstruction, turn the Sten to the right and shake vigorously; the round or empty case should fall out. If it does, and the chamber is clear, go on firing. If the obstruction is still there, or if there is a live round in the chamber, partially remove the magazine and clear the obstruction by shaking or the live round by firing. Cock if necessary, re-engage the magazine, and go on firing.
- (c) A misplaced round in the magazine will be flicked out and any round half-fed in the chamber or in the body shaken out; and in neither case will the round be replaced in the magazine. These rounds will be regarded as damaged, whether any signs are visible or not, and as such will be rejected.

NOTE.—In darkness feel inside the ejection opening to make certain that the obstruction has been removed.

Practise squad. (Words of command: “Sten fires all right”—“Sten stops”—“Obstruction”—“Clear”—“Live round in chamber”, etc.—“Sten fires all right”).

5. **Safety precautions when firing the Sten.**—If the Sten cannot be cocked by hand, remove the magazine, loop a cord or pull-through round the cocking handle and give it a sharp jerk to release it. Carry out the normal immediate action, making certain for safety reasons that the barrel is pointing towards the target.

LESSON 3.—STRIPPING AND CLEANING

Instructor's notes

Stores :—

Sten machine carbine ; magazine ; pull-through ; flannelette and oil ; gauze.

For names of parts, see Plate 6.

1. **Stripping.**—Explain and demonstrate :—

- (a) Cock the Sten and ease the working parts forward. This must always be done before any part is stripped.
- (b) *Butt.*—Press in the stud on the recoil spring housing and slide the butt downwards and off.
- (c) *Bolt.*—Press the cap (or ring) round the stud inwards and turn it anti-clockwise ; this will unlock it from its seating in the body. Remove the cap, spring housing, and spring. Draw the cocking handle to the rear, turn it halfway into the safety slot, and remove it. Slide the bolt out of the body.
- (d) *Barrel (Marks II and V only).*—Pull out the plunger on the side of the magazine housing and turn the housing downwards. Unscrew the barrel and barrel nut (the front hand grip) together and remove.
The Sten will **not** be stripped further than this except to rectify damage.

2. **Assembling.**—Explain and demonstrate :—

- (a) *Barrel.*—Push the barrel on to its seating and screw the barrel nut partially home. Make certain that the line or the three figures on the barrel are roughly in line with the foresight (inaccurate shooting will result if this is not done). Screw the barrel nut fully home and turn the magazine housing back to its normal position.
- (b) *Bolt and spring.*—Hold the Sten horizontally and push the bolt into the body ; then, keeping the trigger pressed, push it forward until the hole for the cocking handle is opposite the safety slot. With one end of the cocking handle as a guide, bring the hole into the correct position and insert the cocking handle. Keep the trigger pressed and slide the bolt forward. (Never *drop* the bolt into the body vertically ; the ejector may be damaged.) Insert the spring and its housing, replace the cap, press it into its slots and turn it clockwise until it engages.

(c) *Butt*.—Press the stud on the recoil spring housing inwards with the top of the butt. Hook the butt catch into its slide, and push upwards till the butt is locked. Cock and test the action.

3. Practise squad.

4. **Stripping the magazine.**—Explain and demonstrate :—

(a) *Stripping*.—Press in the stud on the bottom plate and slide it off, controlling the spring as it comes out. Lift out the spring and platform.

(b) *Assembling*.—Replace the platform and spring, and slide on the bottom plate until the stud engages in the hole in the plate. A tap with the hand will help it to engage.

5. **Cleaning.**

(a) Explain and demonstrate :—Strip the Sten completely. Clean the bore as taught for the rifle, using the pull-through and flannelette size 4 ins. by 3 ins. A gauze is provided but should be used only when absolutely necessary. When the bore is clean, oil it, using flannelette size 4 ins. by 2 ins. Clean and oil the chamber, using the pull-through weight or a piece of stick with flannelette placed on it. Thoroughly clean and oil the rest of the weapon, paying special attention to the following :—

The face of the bolt.

The inside of the body and the ejector.

NOTE.—Before firing the weapon should be completely dry if possible. Unlike the Thompson, the Sten will fire whether dry or oily, but in hot dry climates all oil must be removed before firing.

Clean the magazines with an oily rag. Make certain that the inside of each magazine is perfectly clean and contains no rough projections; also examine the lips to see that they are not damaged. If ammunition is available, make certain that the top round is at the correct angle (*see* Plate 7). Finally test each magazine in the magazine housing to ensure that it will fit.

(b) Practise squad.

6. **Decontamination.**

(a) Explain that if the Sten becomes contaminated by gas it should be cleaned like the rifle (*see* Pamphlet No. 3, lesson 1).

(b) Question squad.

APPENDIX A

THE THOMPSON SUB-MACHINE GUN M.1 (U.S. MODEL)

Troops operating with American forces may meet this weapon, which, in the U.S. Army, is replacing the various types of Thompson machine carbines already described in this pamphlet. The M.1 differs from the earlier types in many respects, the most important of which are :—

- (a) The fixed backsight consists of an aperture *and* a " U " sight.
- (b) The butt cannot be detached from the pistol grip.
- (c) No " H " piece or felt pads are incorporated.
- (d) The cocking handle is similar to that of the Sten and fits into the right side of the bolt.
- (e) The buffer is not integral with the buffer rod ; this simplifies stripping considerably.

Stripping.—Remove the butt and pistol grip together (*see* Thompson, Lesson 3). Press in the rear end of the buffer rod and lift out the buffer. Maintain pressure on the rod and draw the bolt back till its front end is behind the slots in the body. (This will prevent distortion of the spring.) Remove the rod and spring under control. Draw the bolt back till the cocking handle is in line with the enlarged recess in the cocking handle slot. Depress the firing pin hammer, raise the bolt slightly, and remove the cocking handle. Draw the bolt back and lift out.

Assembling.—Replace bolt and cocking handle. Draw the bolt back as for removing the spring. Replace the spring and buffer rod, being careful not to distort the spring. Maintaining pressure on the rod, ease the bolt slowly forward, and replace the buffer. Replace the pistol grip and butt.

Cleaning.—As in Thompson, Lesson 3, except that graphited grease need not be used since there is no " H " piece. Note also that the bolt must be kept well oiled, because there are no felt pads in the body to act as oil reservoirs.

APPENDIX B

FITTING OF THE SPOTLIGHT PROJECTOR

1. For the spotlight projector *see* Pamphlet No. 6. The apparatus can easily be fitted to the Thompson and Sten machine carbines with a few simple additional fittings.

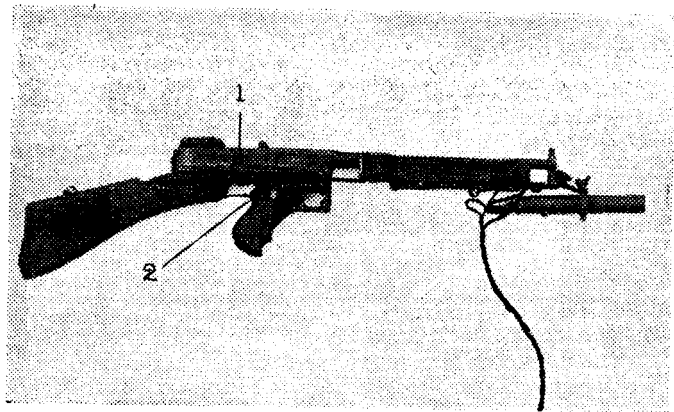

PLATE 10

1. Lead clip.
2. Trigger guard clip.

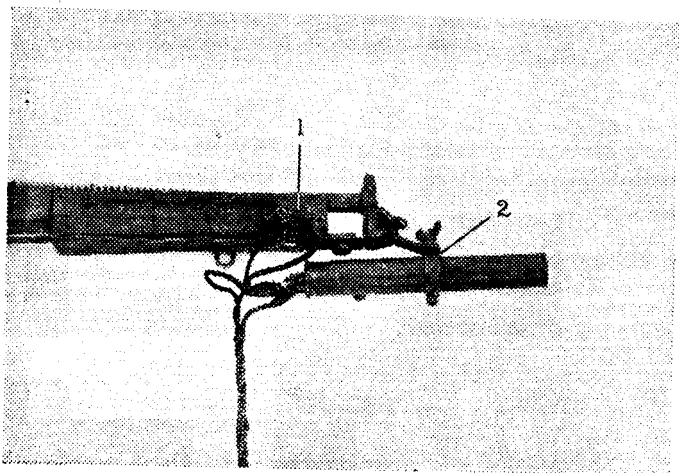

PLATE 11

1. Terminal block.
2. Bracket.

2. Plates 10 and 11 show the projector fitted to the Thompson with horizontal foregrip and no compensator. The only additional requirements are :—

- (a) A trigger guard clip.
- (b) A lead clip.
- (c) A thin metal plate and 2 wood screws.
- (d) Two suitable lengths of insulated wire.

} (See
Plate 12 .

In addition, the spotlight bracket issued for the No. 1 rifle must be modified by the drilling of a small hole 1 in. from the bottom of the slot which fits on to the bayonet standard (Plate 13).

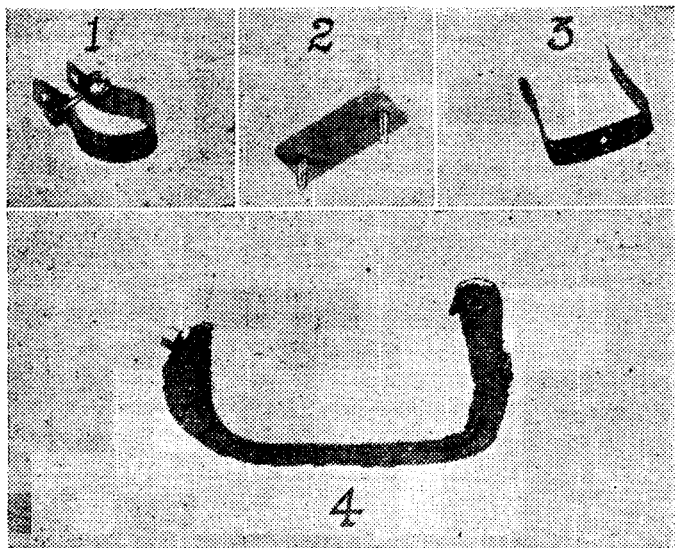

PLATE 12

- 1. Bracket for use with vertical foregrip and compensator.
- 2. Thin metal plate and two wood screws.
- 3. Lead clip.
- 4. Trigger guard clip.

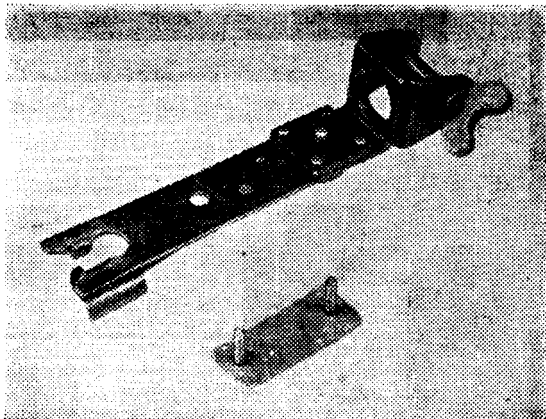

PLATE 13

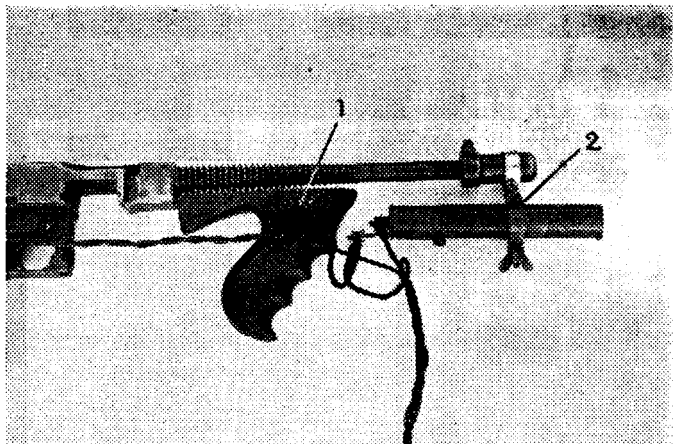

PLATE 14

1. Terminal block.
2. Bracket.

To assemble the apparatus :—

Screw the bracket into the underside of the foregrip with the metal plate and wood screws. Screw the terminal block into the right side of the foregrip.

Fit the trigger guard clip to the trigger guard. (This clip must be insulated so that the small contact screw does not make contact with the trigger guard through the clip). Fit the lead clip to the body behind the pistol grip.

Connect the extra leads to the terminals : connect the other ends to the trigger guard and lead clips. Attach the projector and main leads as for the rifle.

3. Plate 14 shows the projector fitted to the Thompson with vertical foregrip and compensator. In this case a special bracket is necessary (Plate 12). To assemble : fit the bracket to the projector. Slide the bracket over the compensator and tighten the screw. Proceed as in para. 2 (from "Screw the terminal block, etc." to the end of the paragraph).

4. Plates 15 and 16 show the projector fitted to the Sten Mark II.

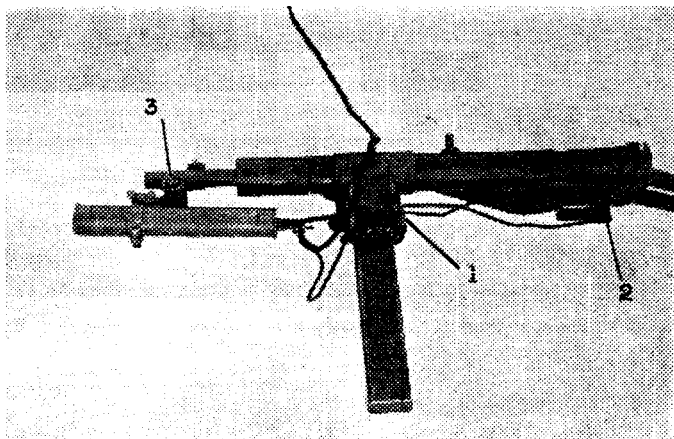

PLATE 15

1. Terminal block with clip.
2. Insulated trigger guard clip.
3. Bracket.

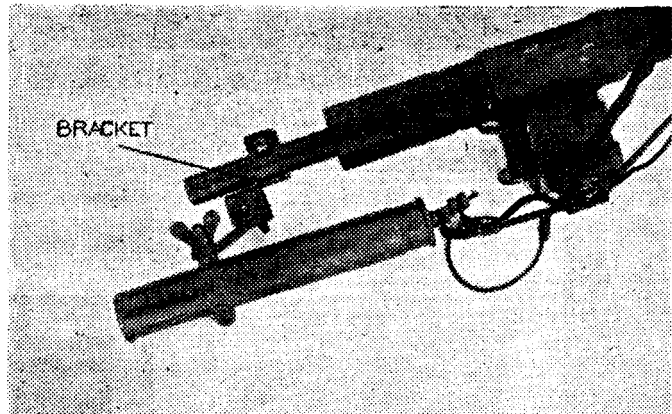

PLATE 16

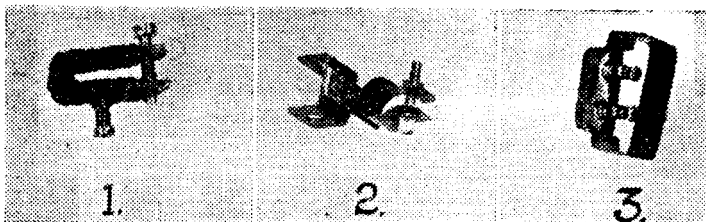

PLATE 17

1. Insulated trigger guard clip.
2. Bracket.
3. Terminal block with spring clip.

Additional fittings required are :—

- (a) A special bracket.
 - (b) A terminal block with spring clip.
 - (c) An insulated trigger guard clip (as in 2 (a) above, modified to fit the Sten trigger guard).
 - (d) Two short lengths of insulated wire.
- } (See Plate 17)

To assemble :—

Fit the bracket over the muzzle and tighten the screw. Fit the terminal block in its clip over the magazine housing. Fit the trigger guard clip to the trigger guard, as in para. 2 above.

Connect the extra leads to the terminals; connect the other ends to the trigger guard clip and to the screw at the front of the trigger mechanism casing.

Attach the projector to the special bracket and connect main leads as for the rifle.

NOTE.—The scale of spotlight projectors is detailed in A.C.I. 567 of 1940 (see reprint notified in A.C.I. 1732 of 1943).

APPENDIX C

STEN MACHINE CARBINE

NEW COCKING HANDLE (Mark IV)

To ensure that the machine carbine shall not be fired by a jolt when the action is forward, an additional safety device, suitable for any mark of Sten machine carbine, is being introduced. See Figs. I and II.

FIG. 1. "FIRE"—COCKING HANDLE IN "OUT" POSITION

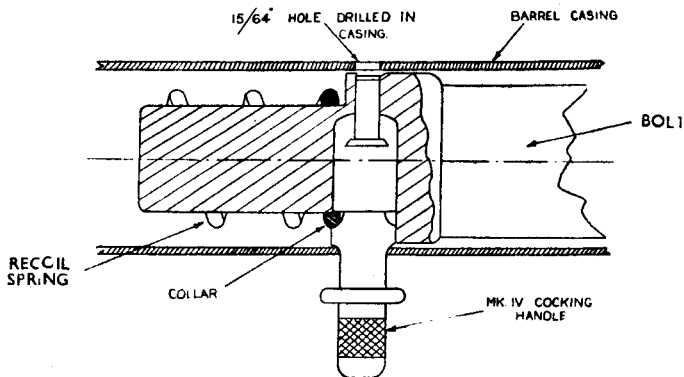

FIG. I.

FIG. II. "SAFE"—COCKING HANDLE LOCKING BOLT TO BARREL CASING.

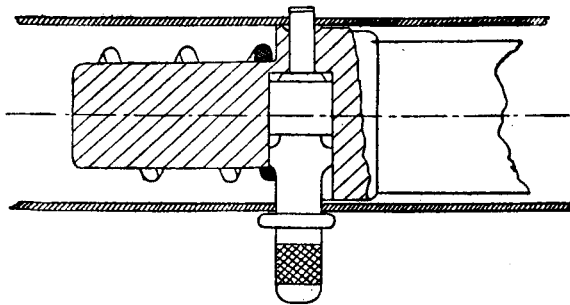

FIG. II.

When the cocking handle is "IN" the bolt is positively locked to the casing. At "OUT" the carbine is free to fire.

To fire, pull out the cocking handle until it clicks into position before cocking.

To make the carbine safe, when the action is forward, tap in the cocking handle with the palm of the hand.

APPENDIX D

DANGER AREA.—THOMPSON AND STEN MACHINE CARBINES

The danger area for these weapons when fired in the open during field exercises will be as shown in the diagrammatic sketch below :—

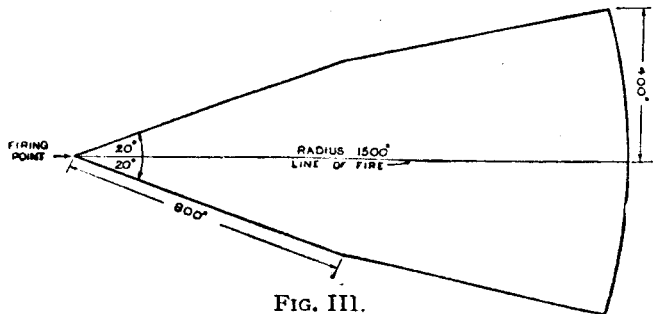

FIG. III.

NOTE.—x against the numbers in the above figure indicates yards. This does not apply when the carbine is fired on 30 yards ranges.