



This manual has been scanned by the
Vickers MG Collection & Research
Association

www.vickersmachinegun.org.uk

If it is of use, please make a donation at:

https://www.paypal.com/cgi-bin/webscr?cmd=s-xclick&hosted_button_id=NKSHEDAMHTJ3G

NOT TO BE PUBLISHED

The information given in this document is not to be communicated, either directly or indirectly, to the Press or to any person not holding an official position in His Majesty's Service.

Notified in
A.C.I.s.
6th June
1913



Small Arms Training
Volume I, Pamphlet No. 24
Projector.
Infantry, Anti-Tank

(1913)

1913

(Proceedings)

Approved for publication by the War Office

[Handwritten signature]

DISTRIBUTION

Infantry, motor bns., recce. regts. and training Units	Scale D
Other arms	Scale B
Infantry O.C.T.U.s	Scale IV
Other O.C.T.U.	Scale II
S.A.S. Hythe	150 copies.
148 Training Brigade	1,000 copies.

CONTENTS

	PAGE
Object	1
General description	1
Training	1
Safety precautions	2
Danger areas	2
Lesson 1.—Maintenance of projector and description of bomb	2
Lesson 2.—Loading, Aiming and Firing	10
Lesson 3.—Handling	16
Appendix A.—Additional notes for instructors	18

SMALL ARMS TRAINING

Volume I, Pamphlet No. 24, 1943

PROJECTOR, INFANTRY, ANTI-TANK (PIAT) (Provisional)

GENERAL NOTES

1. *Object*

The sole object of weapon training is to teach all ranks the most efficient way of handling their weapons in order to kill the enemy. Instructors will always bear this fact in mind, and will continually impress it upon those whom they instruct.

2. *General description*

Weight, $34\frac{1}{2}$ lb. ; length, 39 ins. ; weight of bomb, $2\frac{1}{2}$ lb. Maximum range, 115 yds. in an anti-tank role. With the front support fully extended and the shoulder-piece on the ground, it may be used up to 350 yards as a house-breaker.

3. *Training*

The projector differs radically from other small arms. Initial training must take account of this fact and be exceptionally thorough ; each lesson has, therefore, been designed for two consecutive 40-minute periods in order to allow ample time for practice. More practice still will probably be necessary before men become really proficient. As the weapon is as simple as it is unorthodox, this object, however, should quickly be obtained ; as much time as possible, therefore, should be devoted to firing practice, for which practice shot may be used from the start. Moving targets should be introduced later, if possible.

Battle order will be worn for all lessons.

All instructors must have a thorough knowledge of the contents of Appendix A, particularly the causes of stoppages. It will be noted that many of them can occur only with practice shot, and therefore stoppages are less likely in action than during training. Instructors must always watch keenly for these points, otherwise stoppages will frequently occur during training and men will not gain complete confidence in the weapon.

Further details of the weapon may be found in the pamphlet issued with it, which should be read in conjunction with this

pamphlet. It is not essential, however, to follow rigidly the illustrations of cocking and uncocking contained therein.

4. *Safety precautions*

Before beginning any lesson the instructor will inspect all bombs, fuzes, and carriers.

5. *Danger areas*

When firing practice shot or inert bombs (*see Appendix A, para. 1, ii and iii*) no defined danger area is required. It is only necessary to clear the ground of personnel for about 200 yards in front of the firing point, for a width of about 50 yards on each side of the line of fire.

When firing live H.E. bombs, the danger area as shown must be observed, and no personnel may, in any circumstances, be inside the danger area (defined by a heavy black line) while firing is taking place.

A convenient place for spectators to watch the firing of H.E. is at either of the points marked "A" in the illustration.

The distance F.P. (firing point) to T. (target) should be about 100 yards with a maximum of 115 yards as stated in para. 2 above.

LESSON 1.—MAINTENANCE OF PROJECTOR AND DESCRIPTION OF BOMB

Instructor's notes

Stores :—

Projector with slings attached; drill bomb and carrier; all cleaning materials. (The slings should be attached as some men find that they give the best leverage for cocking.)

The parts of the projector will be named as dealt with (Figs. 1 and 2).

Instructors must understand the general notes and Appendix A before teaching any lesson.

1. *Introduction*

Explain :—

The weapon is called the Projector, **Infantry, Anti-Tank**. It is a light self-cocking weapon designed to stop and knock out enemy A.F.Vs. It is shoulder-controlled and fires a H.E. bomb.

Its chief characteristics are :—

- i. **Mobility.** It can be carried by one man.
- ii. **Short range.** The maximum range against tanks is 115 yards. It can, however, be used against

3

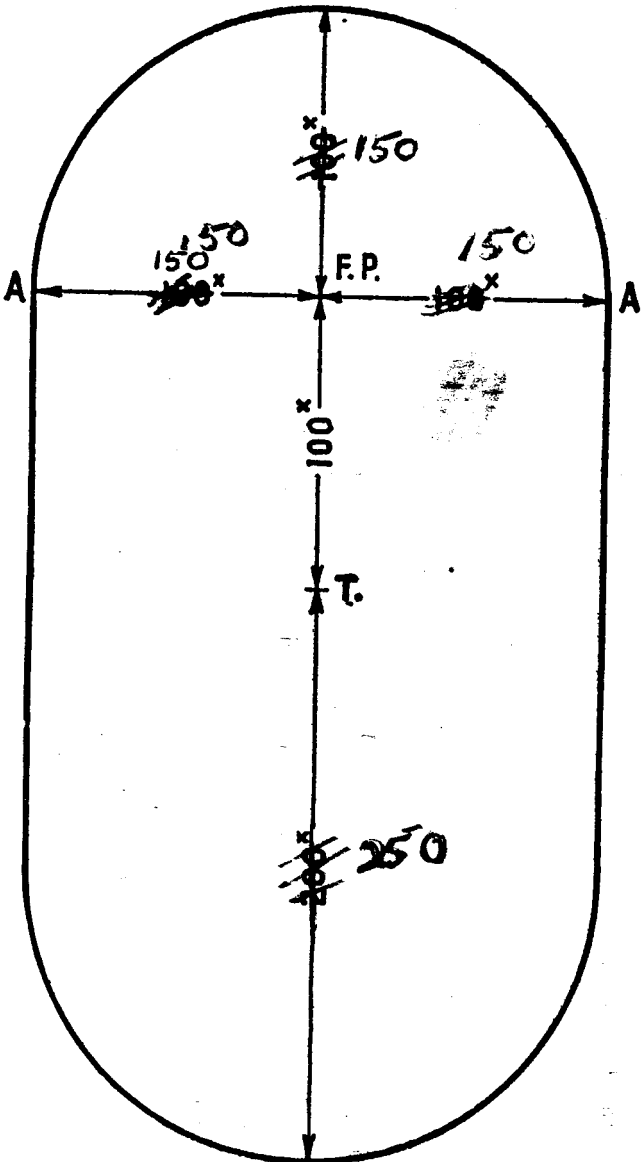

DANGER AREA

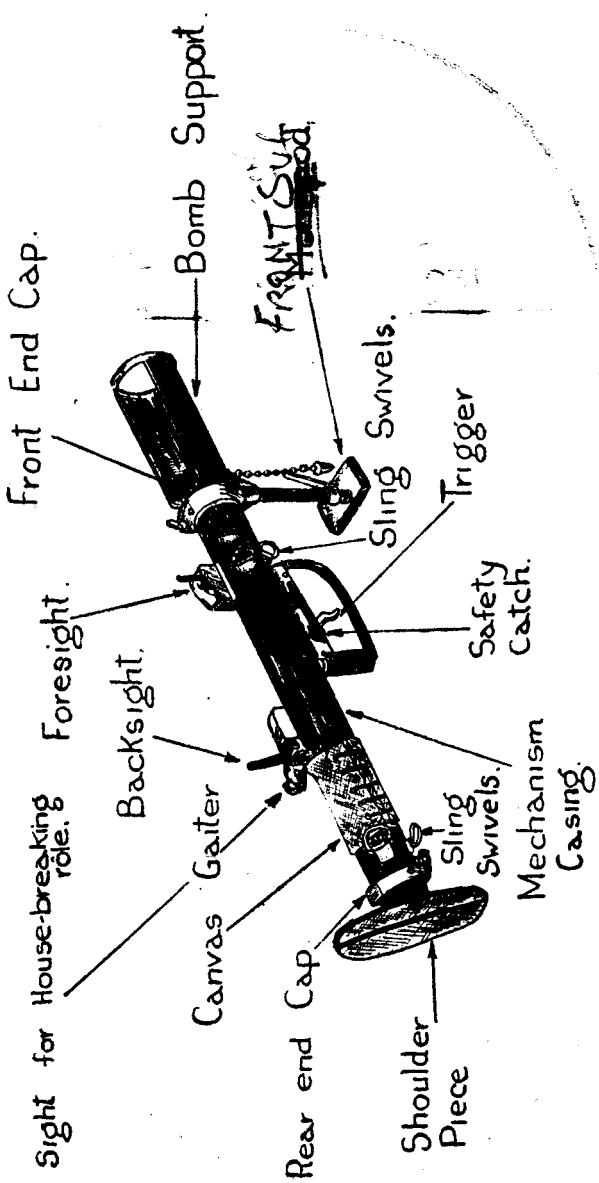

FIG. 1

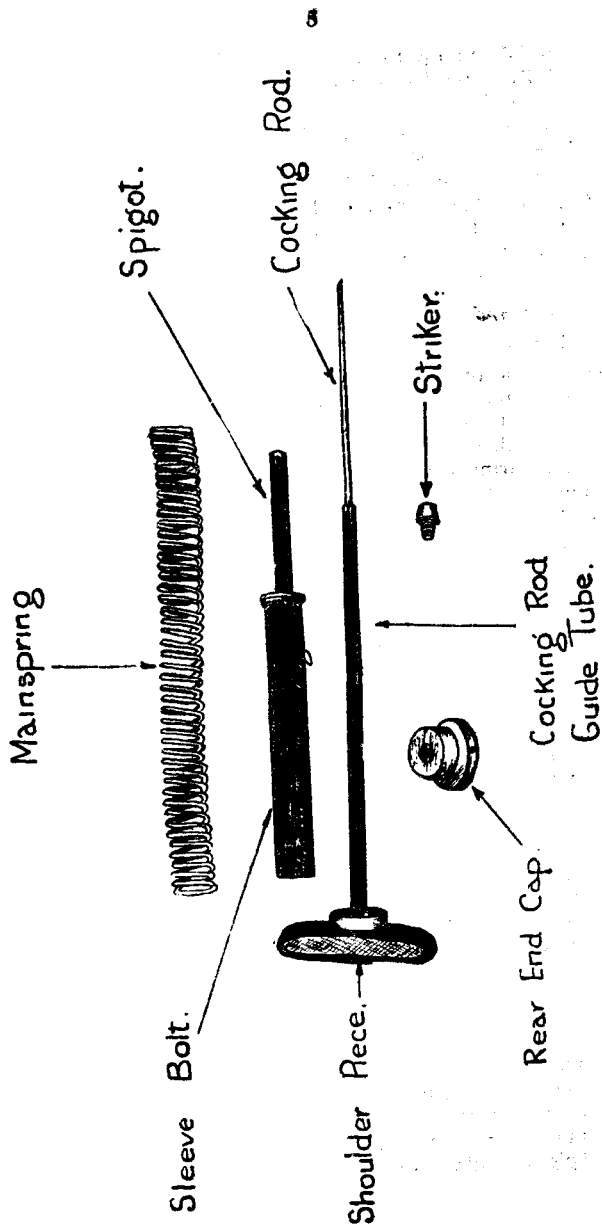

FIG. 2

buildings up to 350 yards, with the front support fully extended and the shoulder piece rested on the ground.

- iii. Excellent penetration. The bomb can penetrate the armour of the latest known types of enemy A.F.Vs. and a considerable thickness of reinforced concrete.

Mechanism.—When fired the weapon is automatically re-cocked, the working parts being forced to the rear by the recoil of the spent cartridge. A strong mainspring eases the shock of recoil on the firer's shoulder.

2. Cocking and uncocking

i. Explain :—

In action the projector will always be carried cocked, with the safety catch applied and the muzzle plug in position. The spring will not suffer damage, however long the weapon remains cocked, but it should be uncocked when opportunity offers, e.g., during periods of rest or for storage. The safety catch must be forward and the sights lowered for cocking and uncocking.

Cocking in the lying position

ii. Explain and demonstrate :—

- (a) *To cock.*—Lie on the back and rest the projector on the chest, with the bomb support pointing over one shoulder and the shoulder piece flat on the ground. Keep the front support clear of the body and arms. Place the insteps on the shoulder piece, one foot on each side of the outer casing. Grasp the trigger guard grip firmly with one hand from underneath; with the other grasp any part of the projector that will give a good leverage. Sit up or bend the knees if necessary, according to the cover. Pull the outer casing away from the shoulder piece and turn it anti-clockwise as far as it will go. Pulling with the hands and pushing with the feet, continue to pull on the outer casing until a click is heard. Considerable effort is required to overcome the resistance of the mainspring. The click denotes that the action is cocked. Push the outer casing back to the shoulder piece; no resistance will be felt. Engage the rear end cap stud in the slot on the shoulder piece body, turning the outer casing if necessary. When the stud is engaged, turn the outer casing clockwise as far as possible. Apply the safety catch and place the muzzle plug in the mouth of the spigot guide tube.

(b) *To uncock.*—Remove the muzzle plug and push the safety catch forward. Draw the outer casing back to its fullest extent as for cocking; no resistance will be felt. Holding the outer casing firmly to overcome the pressure of the mainspring, press the trigger with the thumb and allow the outer casing to go forward under control. Engage the shoulder piece as for cocking.

iii. Practise and question squad.

NOTES.—(a) When cocking and uncocking in this position it may be found easier to re-engage the shoulder piece by hand.

(b) When uncocking the outer casing MUST be allowed to go forward under control; otherwise the weapon may be damaged.

For the same reason the weapon must NEVER be uncocked simply by pressing the trigger.

(c) Since a firm grip is essential, care must be taken to keep the hands away from any position where the sights might be damaged.

Cocking in the standing position

iv. Explain and demonstrate :—

If the cover is high enough the standing position may be used; this allows greater freedom of movement. In this position the projector is held vertically on the shoulder piece, which must be gripped firmly under the insteps and not the toes. The method of cocking and uncocking is exactly the same as for the lying position.

v. Practise and question squad.

3. *Stripping and cleaning*

Explain and demonstrate :—

i. *To strip.*—**SEE THAT THE PROJECTOR IS NOT COCKED.** Lift the spring catch holding the rear end cap in position on the outer casing. Unscrew the rear end cap by turning the shoulder piece and withdraw the working parts. Further stripping will be carried out only by the armourer.

ii. *To clean.*—The weapon is very sensitive to dirt and must be kept clean. It functions best when dry, but will tend to rust if no oil is used. If not immediately required for firing, therefore, it will be left slightly oily; *only the minimum of oil will be used, as over-oiling is as harmful as careless cleaning.* This oil will be removed before firing if possible. Scour out the spigot guide tube with the small brush slightly

oiled, inserting it from the muzzle end. When the tube is clean, dry it out with a piece of rag placed over the brush; leave it slightly oily if necessary. Clean the inside of the outer casing in the same way, using the large brush. Clean the striker, spigot, sleeve bolt and mainspring with a dry rag, leaving them slightly oily if necessary. The spigot must always be kept clean. Finally clean the rest of the projector in the same way.

- iii. *To reassemble.*—Push the working parts into the outer casing as far as possible. Partially press the trigger and push right home. Screw up the rear end cap by turning the shoulder piece. The spring catch will engage automatically; the white lines on the cap and the outer casing should coincide. Cock the projector.

NOTES.—(a) When assembling, do not press the trigger completely, or the sear will rise and prevent the working parts from going forward. The exact pressure needed must be found by trial and error. NEVER USE FORCE.

(b) While screwing on the rear end cap some pressure is required to overcome the resistance of the mainspring; at the same time great care must be taken not to damage the threads, otherwise replacement of the whole outer casing is necessary. Correct assembly may be found easier if the projector is held vertically on the bomb support.

4. Practise and question squad.

5. Bomb (Fig. 3)

Explain and demonstrate:—

- i. *Description.*—The bomb is a high explosive bomb, fired by a cartridge and exploded on impact by a fuze in the nose. On issue it is cartridge but not fuzed. It is coloured green, with a band of red crosses round the body.

The body.—The body is filled with H.E. and has a fuze chamber in the nose. On issue this is filled with a transit plug which is kept in position by a thimble.

The tail unit.—The tail unit consists of a tube with a drum tail attached. The drum tail is composed of four vanes and a ring to steady the bomb in flight. The cartridge is fitted in the front end of the tail tube; on the rear end is clipped a guide ring to ensure correct alignment of the bomb when loaded. The mouth of the tube is closed by a dust plug to exclude dirt.

BOMB

Drum tail



Guide
Ring:

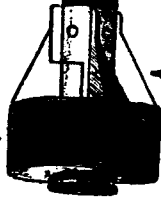

Tail Unit.



Fuze
Chamber.



Body

FIG. 3

The fuze.—Until required for use the fuze is kept in a container attached to the drum tail by a spring clip.

Packing.—Bombs are packed in carriers, each holding three bombs.

- ii. *To fuze.*—Remove the fuze container from the drum tail and take out the fuze. Remove the thimble from the bomb nose by pressing it downwards and turning it clockwise. Remove the transit plug from the fuze chamber and insert the fuze flat end first. Replace the thimble. The transit plug should be placed in the fuze container and the latter put in the carrier, in case the bomb should later have to be unfuzed.

6. Practise and question squad.

7. Carriage

Explain and demonstrate :—

Two pairs of sling swivels are attached to the right side of the outer casing. With two rifle slings fitted to these swivels the projector can be carried on the back, with one sling over each shoulder and the weapon itself resting on the haversack. Alternatively it may be carried slung over one shoulder. In either position the projector should be cocked. It will never be carried with a bomb loaded.

LESSON 2—LOADING, AIMING AND FIRING

Instructor's notes

Stores :—

Projector with slings attached ; drill bomb ; practice shot ; adapter ; spare cartridges and guide rings.

Except for paras. 2 and 7, for which the drill bomb must be used, this lesson should be taught with practice shot throughout if possible. On flat ground an area at least 200 yards long must be clear of persons and livestock while firing is in progress ; the length may be reduced if the ground rises steeply. Any suitable target may be used.

Before the lesson begins the squad must be taught to prepare their practice shot for firing (see Appendix A, 1, ii, and Fig. 4).

After teaching para. 2 the adapter must be fitted. The instructor must ensure that it is fitted correctly (see Appendix A, 1, ii, and Fig. 4), otherwise the projector may not fire. This fact must be emphasized when potential instructors are being trained.

For teaching Immediate Action the projector must be cocked.

PRACTICE SHOT

Screw for fixing to Projector.

Screw-on Steel head.

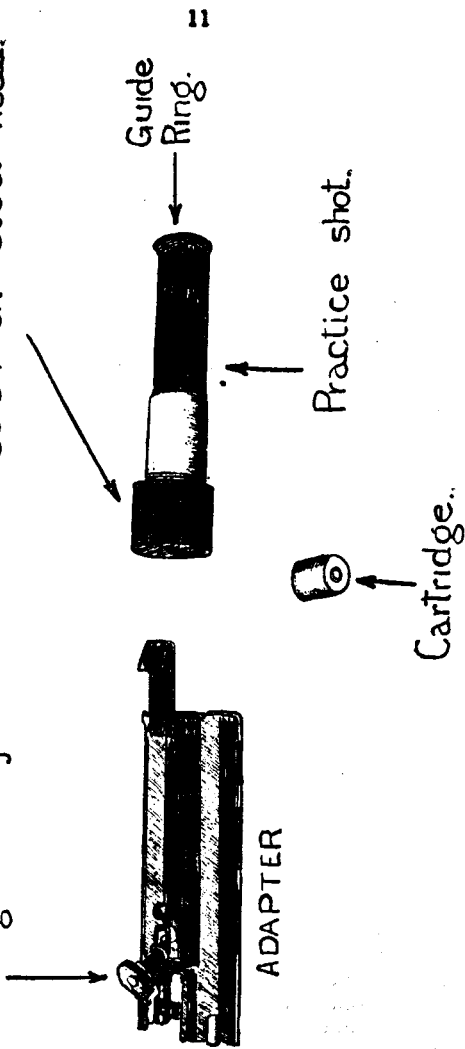

Guide Ring.

Practice shot.

Cartridge.

ADAPTER

FIG. 4

1. Introduction

Explain :—

When choosing a firing position for the projector, it should be remembered that the weapon is easier to swing with a moving target if the elbows are not rested. Owing to its limited range every effort must be made to obtain concealment. A slit trench should be dug whenever time permits.

Two men will be required to maintain the projector in action. No. 1 will fire ; No. 2 will load and assist No. 1 in every other possible way.

2. Loading (Fig. 5)

i. Explain and demonstrate with drill bomb :—

Before loading, see that the projector is cocked. No attempt must EVER be made to place a bomb over a protruding spigot. When time permits No. 2 will also make certain that the guide ring is sound and firm on the bomb tail.

To load, No. 2 removes the dust plug from the bomb tail, then the muzzle plug. With the drum tail to the rear, the bomb is placed in the bomb support nose first so that the guide ring is engaged between the loading guide plates. No. 2 must make certain that the tail is pressed as far down as possible by pressing on the drum tail ring with the flat of his hand ; while doing so he must take care not to place his fingers in front of this ring. No. 2 will immediately prepare another bomb for loading.

ii. Practise squad in pairs.

Explain and demonstrate with practice shot :—

3. Loading. As in para. 2.

4. Sights and aiming

Raise the foresight and backsight. The foresight is in the form of a bead ; the backsight consists of two apertures, the top sighted for 100 yards and the bottom for 70 yards.

Rules for aiming

Against head-on and retiring tanks : keep the foresight in the centre of the aperture and aim at the centre of the tank.

Against crossing tanks : Keep the foresight in the centre of the aperture and aim one length in front of the tank from the centre. The swing of the projector must not be checked at the moment of firing.

These rules must be applied with common sense. Depending on the range and speed of the tank, the lead may have to be lengthened or shortened. Moreover, when using the 100-yard aperture, aiming up and down may be necessary, since a

LOADING



Note - The Monopod will invariably be sunk in the ground.

FIG. 5

comparatively small increase or decrease in range affects the trajectory of the bomb considerably. The top aperture should be used for ranges between 85 and 115 yards, and the bottom one for ranges below 85 yards. It should be noted that the distance from the top of the bead to the shoulder of the foresight, when viewed through the backsight aperture, represents a height of 6 feet at 100 yards.

Errors in lead and elevation can be corrected by practice and observation of fire, which are always essential.

5. Holding and firing (Fig. 6)

Raise the shoulder piece into the shoulder. Push the safety catch forward. Hold the projector firmly into the shoulder with the left hand either over the webbing gaiter or grasping the front of the trigger guard; place the thumb of the right hand behind the trigger guard grip and the first two fingers on the trigger. Aim as taught.

To fire, press the trigger when the aim is correct. The trigger pressure is long and heavy. After pressing the trigger there is an appreciable delay before the bomb is fired; it is essential to maintain correct hold and aim during this delay.

After firing, No. 1 will observe the flight of the bomb. No. 2 will reload immediately, first making certain that the spigot is not showing. Owing to the limited range of the weapon, quick reloading is essential in case the first bomb misses the target. No. 1 must take care to keep his finger clear of the trigger while No. 2 is reloading.

NOTE.—The trigger will NEVER be pressed unless a cart-ridged bomb is loaded.

6. Practise squad in pairs.

7. Immediate action

i. Explain:—

If the projector is properly maintained stoppages will rarely occur. The most likely causes are:—

- (a) *Loose or bent guide ring on the bomb tail.*
- (b) Failure to press the bomb tail fully home when loading.
- (c) Dirt on the spigot.
- (d) Neglect to maintain the correct hold after pressing the trigger will cause failure to recock.

ii. Explain and demonstrate with drill bomb:—

- (a) If the bomb has left the bomb support but the projector has failed to recock, recock and carry on firing.
- (b) If the bomb is still in the bomb support, No. 1 will draw the projector back, move to one side and steady it. No. 2 will place the point of a bayonet between

FIRING

Left hand on
Canvas Gaiter.
or
Front of Trigger Guard.

Monopod.

Two fingers
round
Trigger.

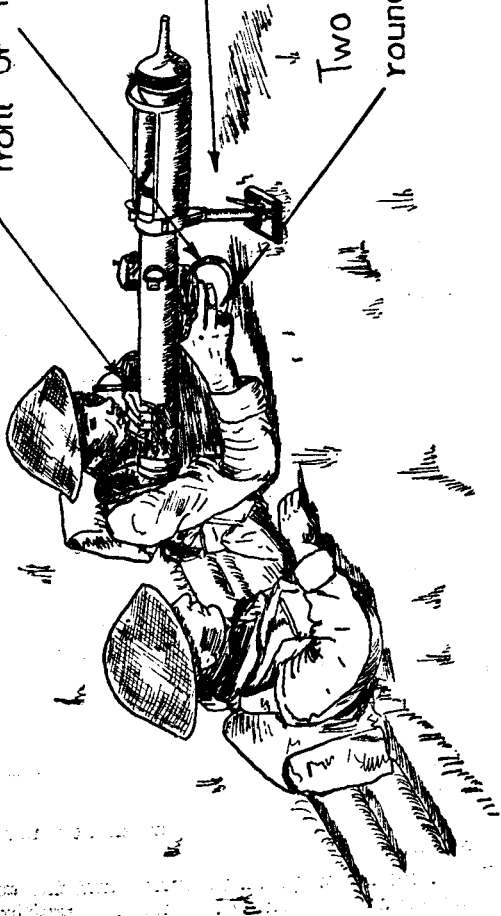

FIG. 6

Note - The Monopod will invariably be sunk in the ground.

the front end cap and the rear edge of the drum tail, and lever the bomb *at least halfway* along the bomb support. It can then be removed by hand. No. 2 will then ensure that the striker is not damaged, and clean the spigot if necessary. Even a thin layer of fouling on the spigot may cause a stoppage. The projector is then recocked and firing continued.

NOTE.—If the bomb is still in the bomb support, it is impossible to tell whether the spigot is fully forward. It may be jammed halfway forward. If so, it may suddenly clear the obstruction and fire the bomb at any moment. No attempt, therefore, must be made to ease the bomb forward by hand until it is halfway along the bomb support, when the cartridge will be out of reach of the striker.

iii. Practise squad in pairs.

8. *Ear protection*

Some form of ear protection is necessary for the Nos. 1 and 2 when firing the projector. No special ear protectors will be issued for this purpose, but cotton wool, four-by-two, or some similar material should be used.

LESSON 3.—HANDLING

Instructor's notes

Stores :—

Projector with slings attached, drill bombs and carriers.

When exercising pairs in handling the instructor will invariably describe a minor tactical situation to stimulate interest.

1. *Explain :—*

The primary role of the projector is anti-tank. Its secondary role is for house breaking. The scale of issue is three per company, in infantry battalions, i.e., held by the company on a scale sufficient to allow each platoon having one if required.

2. *Explain :—*

When siting the projector for use in its primary role the following points must be considered :—

- i. A field of fire of 100 yards or slightly more only is required.
- ii. The necessity of gaining surprise and the consequent importance of a carefully concealed position.

- iii. The desirability of shooting enemy A.F.Vs. from the flank or rear.
- iv. The number of bombs carried will be limited ; it is important, therefore, to get the enemy vehicle well within range to make certain of a " kill."
- v. Probably the normal position for firing will be from a slit trench.

3. Practise squad in pairs as follows :—

Instructor points out the arc of fire and approximate position where the projector is to be mounted ; allows two or three minutes for the squad to consider their action ; and then practises any pair. Particular attention must be given to practising from slit trenches. This will necessitate sinking the monopod as far as possible for concealment.

4. Explain :—

The secondary role of the projector is as a house breaker. Its range is up to 350 yards and both low and high angle are possible. When used in this role the shoulder piece will *always* be positioned horizontally.

Having set the required range on the sight the bubble must be centralized :—

(a) by adjustment of length of ~~monopod~~ ^{FRONT SIGHT} ;

(b) by using ground, e.g., hollows, small mounds, etc., in conjunction with (a).

The white line will give direction, auxiliary aiming marks can be used if essential.

The head, when firing, should be kept down by the side of the projector.

One ranging shot only will usually be sufficient.

5. Practise squad in pairs in the use of the projector in the secondary role.

APPENDIX A

ADDITIONAL NOTES FOR INSTRUCTORS

1. *Training bombs.*i. *Drill bomb.*

This is the same shape and size as the live bomb, but is coloured black and marked "DRILL" in white letters. It is issued with a drill fuze, but is not cartridge'd. The tail tube is plugged. This bomb must be used for drill purposes only; on no account will the plug be removed and the bomb cartridge'd for firing.

ii. *Practice shot (Fig. 4).*

This consists of a steel tube on to which a solid steel head is screwed. Before firing, a cartridge and guide ring must be fitted. It is excellent for training, and can be used any number of times by fitting a fresh cartridge and guide ring each time. The latter must never be used more than once. It must be appreciated that, though the shot is the same weight as the live bomb, the trajectory is flatter; the aim and lead required for direct hits are therefore not the same as for the live bomb. So far as elevation is concerned this difficulty can be overcome by placing the targets at 77 and 113 yards for use with the 70 and 100 yard apertures respectively.

To prepare the shot for firing: Unscrew the steel head. Insert a cartridge CAP FIRST, in the threaded end of the tube. Screw the head FULLY HOME; this action will guide the cartridge into the correct position. Clip a guide ring to the groove on the rear end of the tail.

To clear after firing: Unscrew the head and push the remains of the cartridge out of the chamber with the length of tubing provided. Only tubing must be used, since a solid or pointed implement might fire the cartridge in an unfired or even a misfired shot. The tube must be thoroughly cleaned with the brush provided.

Before firing practice shot the adapter must be fitted to the projector. It is slid along the bomb support until the hook on the front edge engages with the edge of the support; the adapter is then screwed up TIGHT from underneath by the knurled nut. The hinged bar at the rear must be swung ACROSS the adapter. If these instructions are not followed stoppages will occur.

If immediate action is necessary while firing and the shot is still in the bomb support, the point of the bayonet will be placed against the rear of the shot head and the shot tapped forward. The precautions described in Lesson 2, para. 7, must still be taken.

The shot is painted white to make recovery easier after firing. The paint must be renewed from time to time as necessary. Any suitable paint may be used; special ammunition paint is not essential.

Practice shot are issued in boxes of 10, with cleaning brush and clearing tube. Cartridges and guide rings are issued separately.

iii. *Inert bomb.*

This is the same shape, size and weight as the live bomb, but is filled with inert material and has no fuze. It is cartridge ready for use. It is coloured black with a yellow ring round the body, and is marked "INERT" in white letters. It can be fired once only, but its value lies in the fact that its trajectory is the same as that of the live bomb. It must never be used for drill purposes.

Bomb carriers are marked with white or yellow bands, or bands of red crosses, on the containers according to the type of bomb they contain.

2. *Causes of stoppages.*

Apart from mechanical defects or defective cartridges, almost all stoppages can be traced to two main causes:—

- i. Dirt or oil in contact with the spigot, causing it to jam before the striker reaches the cartridge, or between firing and recocking.
- ii. Faulty alignment of the bomb when loaded; the spigot will not enter the tail tube freely and the cartridge may not be struck.

In action, therefore, stoppages may be caused by:—

Group i. (a) Dirt or oil on the spigot or in the spigot guide tube.

(b) Dirt in the bomb tail tube.

Group ii. (a) Loose or deformed guide ring. (This is the most likely cause if the stoppage cannot be accounted for otherwise.)

(b) Bomb tail not pressed fully home when loaded.

(c) Distorted drum tail.

During training, the following additional points must be observed when using practice shot:—

- i. Correct fitting of the adapter (*see* para. 1, ii, above); otherwise the shot will not be correctly aligned when loaded.
- ii. Correct preparation of practice shot, particularly the fitting of the guide ring.

The vital importance of keeping the weapon and ammunition clean, especially the parts mentioned in i. above, must always be remembered. This is more important than ever in dusty and sandy countries.

During training, bombs and practice shot should be kept scrupulously clean before firing. The muzzle plug should always be kept in position when the weapon is cocked; during firing it should be hung over the left side of the outer casing and not be allowed to trail along the ground. This is particularly important when the muzzle plug is continually being removed and replaced, e.g. in loading practice.

3. *Miscellaneous.*

In the early stages of training it may be found that the rear end cap becomes seated slantwise instead of squarely on the shoulder piece, through faulty uncocking; if the stud does not enter the bayonet slot it tends to form a false groove in the shoulder piece body. This may be remedied by stripping the weapon and seating the rear end cap correctly by hand, with an assistant to hold the rear end of the mainspring in compression.

If for any reason the canvas covering has to be removed from the shoulder piece, it must be laced outwards from the centre when replaced. Loose ends left at the centre may become entangled in the rear end cap during cocking and assembling.

When Immediate Action is necessary during training, the instructor must see that No. 1 draws the projector back in a straight line and does not swing the muzzle out to the right. Failure to take this precaution may cause bombs or practice shot to be fired outside the cleared area.

When live bombs are used for training, blinds must be destroyed. The demolition set described in Pamphlet No. 13 is suitable. All instructors supervising such training must be familiar with Lesson 10 of that pamphlet, also the relevant parts of Appendix II.